

Stainless Steel Submersible Drainage Pumps Single Vane Impeller with 2" Solid Size Combined 2" and 2 1/2" Discharge

CTP 50 M

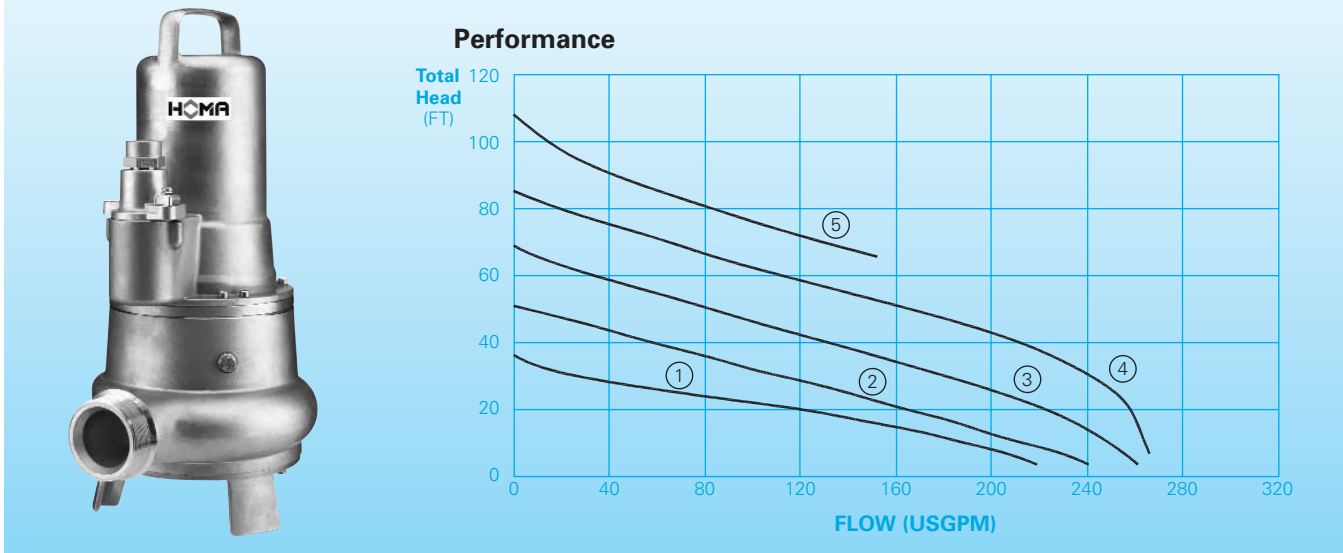

Application

HOMA CTP 50 stainless steel submersible drainage pumps are suitable for pumping corrosive, abrasive or chemically aggressive liquids^{*)}, waste water or sewage and chemicals^{*)} containing soft solids up to 2" diameter. They are used in various domestic, industrial or municipal applications.

Typical Fluids Handled are:

- Drainage water
- Effluent with soft solids
- Chemically aggressive liquids^{*)}
- Liquids to 140 F can be handled intermittently*

CTP 50 Series Pumps are typically used in:

- Residential and Commercial Sewage
- Industrial Wastewater
- Effluent Distribution Systems
- Agricultural Wastewater
- Pond or Lake Water
- Processing Plants
- Optional Factory Mutual (FM) label for Class I, Div 1 EX construction.

* According to specific chemical resistance of used materials

Features

Integral Lift Handle is arched to permit self centering of lifting device

Pump- and Motor Housing Made of stainless steel for maximum chemical resistance^{*)}

Extra Long Replaceable power cable of 33' length is retained and sealed with a strain relief gland

Standard Lower Seal material is Silicon Carbide

Shown: Integral Mounting Stand for transportable applications. Optional: HOMA AutoCoupling System for permanent installations

Upper and Lower High Capacity Ball Bearings assure long life and reliability

Motor windings provided with Class H insulation and fully protected by embedded auto reset thermal switches

Oil Filled Seal Chamber positively lubricates seals and permits a seal leakage probe to be installed

Stainless Steel Single Vane Impeller for large solids handling

Replaceable volute wear ring in single vane pump permits hydraulic efficiency to be restored for long service life

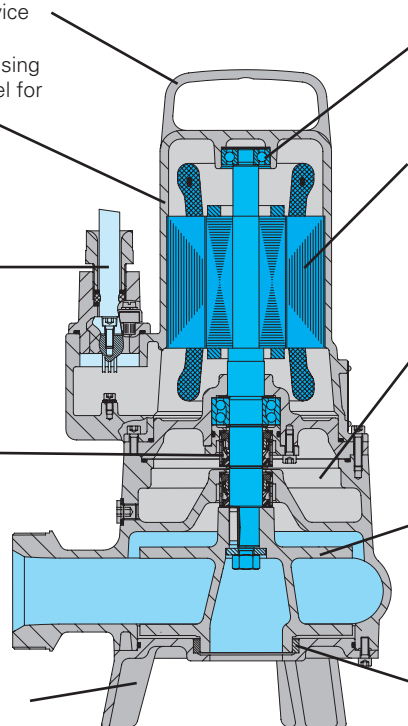

Motor Construction

Motor Type:
 Enclosed Submersible
NEMA Insulation Code:
 Class H
Service Factor:
 1.15
NEMA Design Type:
 B
Standard Cable Length:
 33 ft
Available Motor Voltages:
 1 Phase: 200 V, 230 V
 3 Phase: 200 V, 230 V, 380 V,
 460 V, 575 V
Optional Explosion Proof
 construction:
 Factory Mutual approved for Class I,
 Div. 1, Group C & D.

Materials

Motor Housing, Volute and Impeller
 Stainless Steel AISI 316
Mechanical Seals – Impeller side
 Silicon Carbide vs Silicon Carbide,
 Viton
Shaft Seal – Motor side
 Mechanical Seal
 Silicon Carbide vs Silicon Carbide,
 Viton
O-Rings: FPM (Viton)
Upper Bearing:
 Deep groove Ball Bearing
Lower Bearing:
 Double row angular Ball Bearing
Power Cable Protective Hose:
 Polyolefine
Shaft: AISI 430 F
Fasteners: AISI 304 SS

Installations

Wet pit with autocoupling

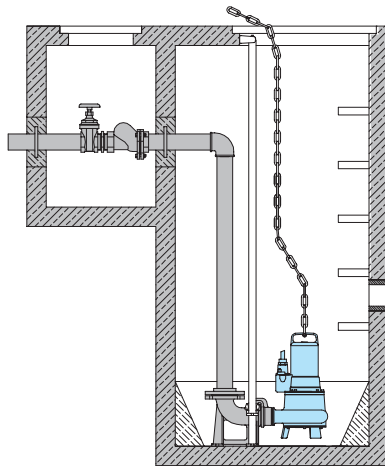

Basestand

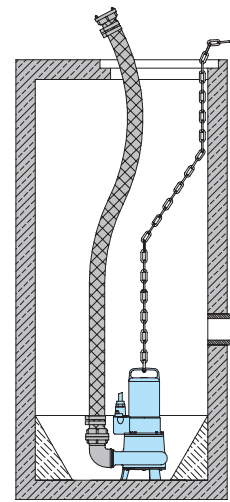

Dimensions (inches) (Tolerance +/- 1/4")

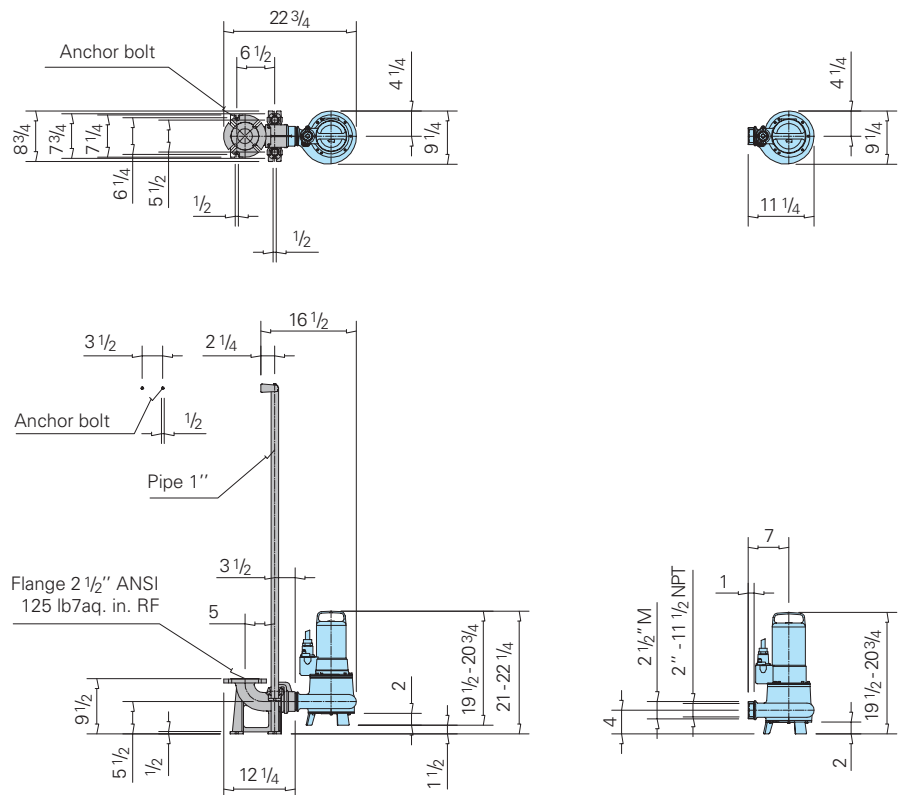

Technical Data

Curve No.	Pump Type	Rated B.H.P.	Phase	Voltage (V)	Full Load Amps	Speed (rpm)	Weight (LBS)	NEMA code
1	CTP50M20/4/3	1.6	3	230/380/460	5.2/3.2/2.6	1750	86	H
2	CTP50M29/2/3	2.3	3	230/380/460	7.0/4.2/3.5	3450	86	G
3	CTP50M38/2/3	3.0	3	230/380/460	8.2/5.0/4.1	3450	86	G
4	CTP50M54L/2/3	4.3	3	230/380/460	11.4/6.9/5.7	3450	112	F
5	CTP50M54H/2/3	4.3	3	230/380/460	11.4/6.9/5.7	3450	112	F