

Installation, Operation, and Maintenance Manual

GRP Series

Version 11/2021- No. 00507610.02



Content

1.2. Preface	03
1.3. Proper use.....	03
1.4. Copyright.....	03
1.5. Technical terms.....	03
2. Safety.....	03
2.1. Instructions and safety information.....	03
2.2. General safety.....	04
2.3. Operating personnel	04
2.4. Electrical work	04
2.5. Operating procedure.....	05
2.6. Safety and control devices.....	05
2.7. Operation in an explosive atmosphere.....	05
2.8. Sound Safety.....	05
2.9. Pumped fluids	06
2.10. Danger due to spark generation	06
3. General description	06
3.1. Application.....	06
3.2. Types of use	06
3.3. Construction	06
4. Package, Transport, Storage	09
4.1. Delivery	09
4.2. Transport	09
4.3. Storage	09
4.4. Returning to the supplier	10
5. Installation and initial commissioning	10
5.1. General.....	10
5.2. Installation	11
5.3. Use of chains.....	13
5.4. Initial operation	13
5.5. Preparatory work	13
5.6. Electrical	14
5.7. Direction of rotation.....	15
5.8. Motor protection.....	15
5.9. Variable Frequency Drives.....	15
5.10. Types of startups	15
6. Maintenance.....	16
6.1. General.....	16
6.2 Maintenance intervals	17
6.3. Maintenance tasks	17
6.4. Sealing chamber	18
7. Repairs	19
7.1. General	19
7.2. Changing the impeller	19
7.3 Spare Parts	19
8. Shutdown.....	20
8.1. Temporary shutdown.....	20
8.2. Final shutdown / storage	20
8.3. Restarting after an extended period of storage	20
9. Troubleshooting	21
10. Connection of pumps and mixers	23

1.2. Preface

Dear Customer,

Thank you for choosing one of our company's products. You have purchased a product which has been manufactured to the latest technical standards. Read this operating and maintenance manual carefully before first use in order to ensure that the product is used safely. The documentation contains all the necessary specifications for the product, allowing you to use it properly. In addition, you will also find information on how to recognize potential dangers, reduce repair costs and downtime, and increase the reliability and working life of the product.

All safety requirements and specific manufacturer's requirements must be fulfilled before the product is put into operation. This operating and maintenance manual supplements any existing national regulations on industrial safety and accident prevention. This manual must also be accessible to personnel at all times and also be made available where the product is used.

1.3. Proper use

In the event of improper use, there is a danger to life for the user as well as for third parties. Additionally, the product and/or attachments may be damaged or destroyed.

It is important to ensure that the product is only operated in good condition and as intended. To do so, follow the operating instructions. The pumps can be used in the range specified by the manufacturer, in accordance with the current HOPSEL version. Please note that the offered pumps may only be used in the defined field of application. Operating the pump outside the application range can lead to operational problems or significant damage to the unit.

1.4. Copyright

This operation and maintenance manual has been copyrighted by the manufacturer. This operation and maintenance handbook is intended for use by assembly, operating and maintenance personnel. It contains technical specifications and diagrams which may not be reproduced or distributed, either completely or in part, or used for any other purpose without the expressed consent of the manufacturer.

1.5. Technical terms

Various technical terms are used in this operating and maintenance manual.

Dry run

The product is running at full speed, however, there is no liquid to be pumped. A dry run is to be strictly avoided. If necessary, a safety device must be installed.

"wet" installation type

This installation type requires the product to be immersed in the pumped fluid. It is completely surrounded by the pumped fluid. Please observe the values for the maximum submersion depth and the minimum water coverage.

"dry" installation type

In this installation type, the product is installed dry, i.e. the pumped fluid is delivered to and discharged via a pipeline system. The product is not immersed in the pumped fluid. Please note that the surfaces of the product become very hot!

"transportable" installation type

With this installation type the product is equipped with a pedestal. It can be installed and operated at any location. Please observe the values for the maximum submersion depth and the minimum water coverage, and remember that the surfaces of the product become very hot.

"S1" operating mode (continuous operation)

At the rated load, a constant temperature is reached that does not increase even in prolonged operation. The operating equipment can operate uninterruptedly at the rated load without exceeding the maximum permissible temperature.

Operating mode "S3" (intermittent operation):

For this operating mode, after the abbreviation, the percent duty cycle is displayed, as well as the cycle duration if it is greater than 10 minutes. For example S3 40% means the pump can operate continuously for 40% (24 minutes) of one hour, and must then pause for 36 minutes.

Low Level Lockout

The low level lockout is designed to automatically shut down the product if the water level falls below the minimum water coverage value of the product. This is made possible by installing a float switch.

Level control

The level control is designed to switch the product on or off depending on the water level. This is made possible by installing a float switch.

2. Safety

This chapter lists all the generally applicable safety instructions and technical information. Additionally, other chapters contain specific safety instructions and technical information. All instructions and information must be observed and followed during the various phases of the product's lifecycle (installation, operation, maintenance, transport etc.). The operator is responsible for ensuring that personnel follow these instructions and guidelines.

2.1. Instructions and safety information

This manual uses instructions and safety information for preventing injury and damage to property.

To make this clear for the personnel, the instructions and safety information are distinguished as follows:

Each safety instruction begins with one of the following signal words:

Danger: Serious or fatal injuries can occur!

Warning: Serious injuries can occur!

Caution: Injuries can occur!

Caution (Instruction without symbol): Serious damage to property can occur, including irreparable damage!

Safety instructions begin with a signal word and description of the hazard, followed by the hazard source and potential consequences, and end with information on preventing it.

2.2. General safety

- Never work alone when installing or removing the product.
- The machine must always be switched off before any work is performed on it (assembly, dismantling, maintenance, installation). The machine must be disconnected from the electrical system and secured against being switched on again. All rotating parts must be at a standstill.
- The operator should inform his/her superior immediately should any defects or irregularities occur.
- It is of vital importance that the system is shut down immediately by the operator if any problems arise which may endanger safety of personnel. Problems of this kind include:
 - Failure of the safety and/or control devices
 - Damage to critical parts
 - Damage to electric installations, cables and insulation.
- Tools and other objects should be kept in a place reserved for them so that they can be found quickly.
- Sufficient ventilation must be provided in enclosed rooms.
- When welding or working with electronic devices, ensure that there is no danger of explosion.
- Only use fastening devices which are legally defined as such and officially approved.
- The fastening devices should be suitable for the conditions of use (weather, hooking system, load, etc). If these are separated from the machine after use, they should be expressly marked as fastening devices. Otherwise they should be carefully stored.
- Mobile working equipment for lifting loads should be used in a manner that ensures the stability of the working apparatus during operation.
- When using mobile working equipment for lifting non guided loads, measures should be taken to avoid tipping and sliding etc.
- Measures should be taken that no person is ever directly beneath a suspended load. Furthermore, it is also prohibited to move suspended loads over workplaces where people are present.
- If mobile working equipment is used for lifting loads, a second person should be present to coordinate the procedure if needed (for example if the operator's field of vision is blocked).
- The load to be lifted must be transported in such a manner that nobody can be injured in the case of a power cut. Additionally, when working outdoors, such procedures must be interrupted immediately if weather conditions worsen.



These instructions must be strictly observed. Non-observance can result in injury or serious damage to property. This product may contain chemicals known to the State of California to cause cancer and birth defects or other reproductive harm. www.p65warnings.ca.gov

Ces instructions doivent être strictement respectées. Le non-respect de cette consigne peut entraîner des blessures ou des dommages matériels importants. Ce produit peut contenir des produits chimiques connus dans l'État de Californie pour provoquer des cancers et des malformations congénitales ou d'autres problèmes de reproduction. www.p65warnings.ca.gov

2.3. Operating personnel

All personnel who work on or with the product must be qualified for such work; electrical work, for example may only be carried out by a qualified electrician. The entire personnel must be of age.

Operating and maintenance personnel must also work according to local accident prevention regulations. It must be ensured that personnel have read and understood the instructions in this operating and Maintenance handbook; if necessary this manual must be ordered from the manufacturer in the required language.

2.4. Electrical work

Our electrical products are operated with alternating or industrial high-voltage current. The local regulations (e.g. 2017 NEC) must be adhered to. The technical specifications must be strictly adhered to. If the machine has been switched off by a protective device, it must not be switched on again until the error has been corrected.



Beware of electrical current!

Incorrectly performed electrical work can result in fatal injury! This work may only be carried out by a qualified electrician.

Attention au courant électrique !

Des travaux électriques incorrectement effectués peuvent entraîner des blessures mortelles ! Ce travail ne doit être effectué que par un électricien qualifié.



Beware of Moisture!

Moisture penetrating into cables can damage them and render them useless. Additionally, water can penetrate into the terminal compartment or motor and cause damage to the terminals or the winding. Never immerse cable ends in the pumped fluid or other liquids.

Attention à l'humidité !

L'humidité qui pénètre dans les câbles peut les endommager et les rendre inutilisables. De plus, l'eau peut pénétrer dans le compartiment des bornes ou dans le moteur et endommager les bornes ou le bobinage. Ne jamais immerger les extrémités des câbles dans le fluide pompé ou dans d'autres liquides.

2.4.1. Electrical connection

When the machine is connected to the electrical control panel, especially when electronic devices such as soft startup control or frequency drives are used, the relay manufacturer's specifications must be followed in order to conform to EMC. Special separate shielding measures e.g. special cables may be necessary for the power supply and control cables.

The connections may only be made if the equipment meets NEC standards. Mobile radio equipment may cause malfunctions.



Beware of electromagnetic radiation!

Electromagnetic radiation can pose a fatal risk for people with pacemakers. Put up appropriate signs and make sure anyone affected is aware of the danger.

Attention aux rayonnements électromagnétiques !

Les rayonnements électromagnétiques peuvent constituer un risque mortel pour les personnes portant un stimulateur cardiaque. Placez des panneaux appropriés et assurez-vous que toute personne concernée est consciente du danger.

2.4.2. Ground connection

Our products (machine including protective devices and operating position, auxiliary hoisting gear) must always be grounded. If there is a possibility that people can come into contact with the machine and the pumped liquid (e.g. at construction sites), the grounded connection must be additionally equipped with a fault current protection device. The electrical motors conform to motor protection class IP 68 in accordance with the valid norms.

2.5. Operating procedure

When operating the product, always follow the locally applicable laws and regulations for work safety, accident prevention and handling electrical machinery. To help to ensure safe working practice, the responsibilities of employees should be clearly set out by the owner. All personnel are responsible for ensuring that regulations are observed. Certain parts such as the rotor and impeller rotate during operation in order to pump the fluid. Certain materials can cause very sharp edges on these parts.



Beware of rotating parts!

The moving parts can crush and sever limbs. Never reach into the pump unit or the moving parts during operation. Switch off the machine and let the moving parts come to a rest before maintenance or repair work!

Attention aux pièces en rotation !

Les pièces mobiles peuvent écraser et trancher des membres. Ne jamais mettre les mains dans l'unité de pompage ou dans les parties mobiles pendant le fonctionnement. Avant toute opération d'entretien ou de réparation, éteignez la machine et laissez les pièces mobiles s'arrêter !

2.6. Safety and control devices

Our products are equipped with various safety and control devices. These include, for example, moisture sensors and temperature sensors. These devices must never be dismantled or disabled. Equipment such as thermo sensors, float switches, etc. must be checked by an electrician for proper functioning before start-up (see the "Electrical Connection" data sheet). Please remember equipment such as PT100 temperature monitors or float switches require the use of a HOMA GO switch for connection. Please contact your HOMA distributor for information. Personnel must be informed of the installations used and how they work.



Caution!

Never operate the machine if the safety and monitoring devices have been removed or damaged, or if they do not work.

Mise en garde!

Ne jamais utiliser la machine si les dispositifs de sécurité et de contrôle ont été retirés ou endommagés, ou s'ils ne fonctionnent pas.

2.7. Operation in an explosive atmosphere

Products marked as FM approved for suitable operation in an explosive atmosphere, are designed for Class I, Division 1, Groups C and D and Temperature class T4. The permitted ambient temperature is between -4°F and 104°F. The enclosure's protection class is IP68. The products must meet certain guidelines for this type of use. Certain rules of conduct and guidelines must be adhered to by the operator as well. Products that have been approved for operation in an explosive atmosphere are marked as explosion-proof rated by FM. In addition, an "FM" symbol must be included on the name plate!

2.8. Sound Safety

Depending on the size and capacity (kW), the products produce a sound pressure of up to 110 dB. The actual sound pressure, however, depends on several factors. These include, for example, the installation type (wet, dry, transportable), fastening of accessories (e.g. suspension unit) and pipeline, operating site, immersion depth, etc. Once the product has been installed, we recommend that the operator make additional measurements under all operating conditions.



Caution: Wear ear protectors!

In accordance with the laws in effect, guidelines, standards and regulations, ear protection must be worn if the sound pressure is greater than 85 dB (A)! The operator is responsible for ensuring that this is observed!

Mise en garde : Portez des protecteurs auditifs !

Conformément aux lois en vigueur, aux directives, aux normes et aux règlements, le port de protecteurs d'oreilles est obligatoire si la pression acoustique est supérieure à 85 dB (A) ! L'opérateur est responsable du respect de cette consigne !

2.9. Pumped fluids

Each pumped fluid differs in regard to composition, corrosiveness, abrasiveness, TS content and many other aspects. Generally, our products can be used for many applications. For more precise details, see chapter 3, the machine data sheet and the order confirmation. It should be remembered that if the density, viscosity or the general composition change, this can also alter many parameters of the product. Different materials and impeller shapes are required for different pumped fluids. The more exact your specifications on your order, the more exactly we can modify our product to meet your requirements.

If the area of application and/or the pumped fluid change, we will be happy to offer supportive advice.

When switching the product into another pumped fluid, observe the following points:

- Products which have been operated in sewage or waste water must be thoroughly cleaned with pure water or drinking water before use.
- Products which have pumped fluids which are hazardous to health must always be decontaminated before changing to a new fluid. Also clarify whether the product may be used in a different pumped fluid.
- With products which have been operated with a lubricant or cooling fluid (such as oil), this can escape into the pumped fluid if the mechanical shaft seal is defective.



Danger - explosive fluids!

It is absolutely prohibited to pump explosive liquids (e.g. gasoline, kerosene, etc.). The products are not designed for these liquids!

Danger - fluides explosifs !

Il est absolument interdit de pomper des liquides explosifs (par exemple, de l'essence, du kérosène, etc.). Les produits ne sont pas conçus pour ces liquides !

2.10. Danger due to spark generation

Mechanically generated sparks can ignite flammable gases and condensates. According to EN1127-1 Para.6.4.4, sparks must also be excluded for category 2 in normal operation. In normal operation no spark generation is possible due to fluid covering (medium covering of the pump hydraulic). The ingress or suction of foreign bodies (stones, pieces of metal, etc.) through the suction nozzles into the pump hydraulic is not possible in an expected case of malfunction in which the enclosure fails as the pump cannot suck up pumping medium nor its containing solids. In the ventilated shaft, the explosion-protected submersible motor pumps are drained via a drain system with two guide tubes of galvanized steel, between their guide claws of grey cast iron that guide into the automatic coupling arrangement. The guide velocity, with max 0.1 m/s (10cm/s) is so low that no sparks can be generated even in the most disadvantaged conditions. In the first installation, the guide claws of the drain arrangement should be lubricated with ball bearing grease in order to suppress heat and spark generation in the most disadvantaged case.

3. General description

3.1. Application

Waste water disposal with small pipework cross-sections, good delivery heads at relatively low flow rates and pressure drainage systems in areas with difficult topography. GRP pumps shred solids in the pumped medium in next to no time, so plastic pipework with a cross-section as small as 2" can be used.

This significantly reduces the cost of materials and laying the waste water systems. If the pumped medium contains corrosive substances, the corrosion resistance of the materials used must be observed. For such applications, versions made partly or entirely of highly resistant materials (stainless steel) are also available

According to the type of installation and motor cooling, the machine must be submerged in pumped liquid at least up to the top edge of the pump or motor housing.

For continuous operation (S1) without a cooling jacket, the motor housing must be completely submerged.

The temperature of the pumped medium may be up to 104°F or up to 140°F for a short period. The maximum density of the medium is 0.03757 lbs/in³ and the pH may be from 6 – 11. Stainless steel variants can be used at a pH of 4- 14. However, the pH alone only serves as a guideline. Consult factory for assistance with chemically aggressive liquids. Depending on the composition, it may be necessary to use special sealing materials.

3.2. Types of use

The motors are designed for continuous operation (S1), maximum 15 starts per hour. The hydraulic is designed for permanent operation, e.g. supply of industrial water.

3.3. Construction

The major pump components consist of the motor housing, volute, and impeller.

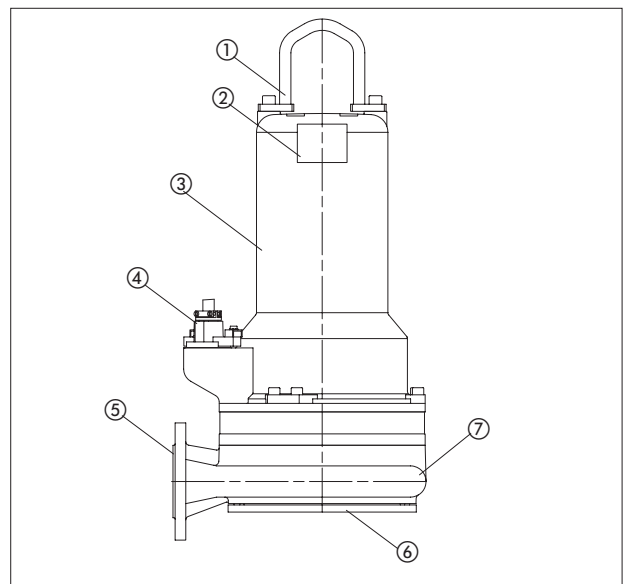

No.	Description
1	Lifting handle
2	Name plate
3	Motor housing
4	Cable inlet
5	Discharge
6	Suction piece with cutting system
7	Volute

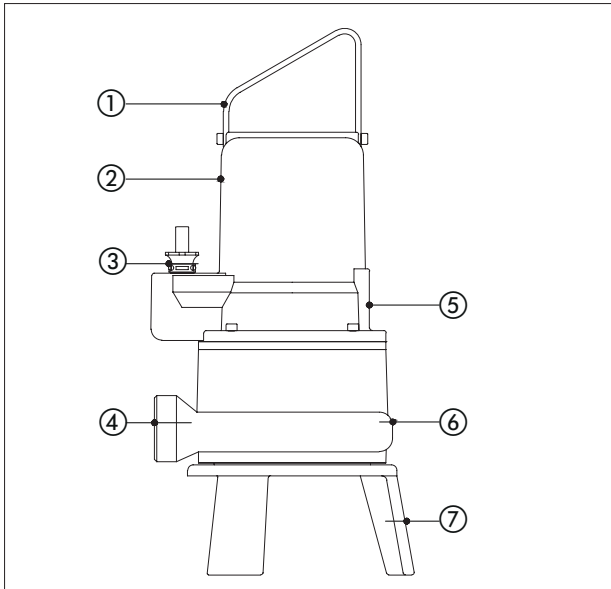

No.	Description
1	Lifting handle
2	Motor housing
3	Cable inlet
4	Discharge
5	Name plate
6	Volute
7	Suction cover with feet

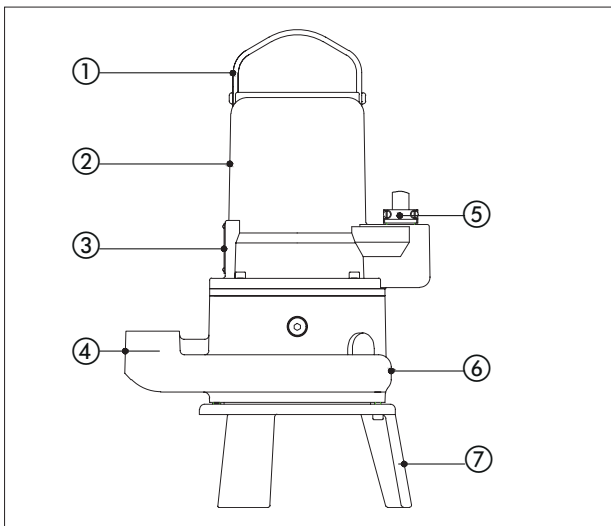

No.	Description
1	Lifting handle
2	Motor housing
3	Name plate
4	Discharge
5	Cable inlet
6	Volute
7	Suction cover with feet

3.3.1. Type label

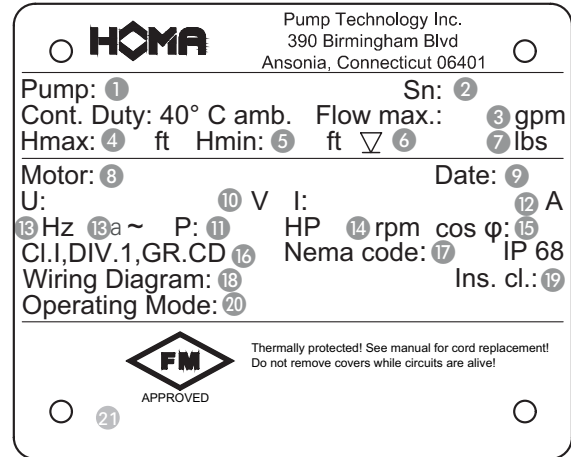

No.	Description
①	Pump name
②	Serial number
③	Flow max
④	Hmax (Head max)
⑤	Hmin (Head min)
⑥	Submersion depth
⑦	Weight
⑧	Motor name
⑨	Date of manufacture
⑩	Voltage
⑪	Motor Power
⑫	Nominal current
⑬	Frequency
⑬ a	Phase
⑭	Motor speed
⑮	Cos phi
⑯	Temperature class
⑰	Nema Code Letter
⑱	Wiring diagram
⑲	Insulation class
⑳	Operating mode
㉑	Comments

3.3.2. Motor

The pump motor consists of the stator and shaft with impeller assembly. The cable for the power supply is designed for maximum mechanical performance in accordance with the characteristic or pump name plate. Both the cable entries and the cable are water-pressure tight to the depth provided on the name plate. The shaft bearing assembly is supported via robust, maintenance-free and permanently lubricated roller bearings. All motors can also be delivered in an explosion-proof version in accordance with FM Class I, Division 1, Groups C & D.

General motor data	
Service factor	1.15
Operating mode	S1
Operating mode at 208V only if a 208V motor was ordered	S3 42% 60min
Max. liquid temperature	35°C / 95°F
Insulation class	H (180°C / 356°F)
Degree of protection	IP68
Cable length	32 ft
Rotor shaft seal	Silicon-carbide / Silicon-carbide
Rotor shaft seal GRP10-21	Silicon-carbide / Buna N
Mechanical shaft seal	Silicon-carbide / Silicon-carbide
Bearing	One grooved ball bearing (above), double-row type angular ball bearing (below)

3.3.3. Monitoring Equipment

The unit is equipped with various types of monitoring-safety equipment. The following table shows an overview of the options available. The options may vary depending on the size of the pressure outlet

Motor type	Motor version
.../C	Temperature monitoring in the winding, Oil chamber seal conditions sensor
...FM	Temperature monitoring in the winding, Explosion proof
.../C FM	Temperature monitoring in the winding, Oil chamber seal conditions sensor and motor connecting chamber, Explosion proof
ET...	Jacket cooled motor, thermal monitoring of winding, monitoring of oil chamber seal
ET... FM	Jacket cooled motor, thermal monitoring of winding, monitoring of oil chamber seal, explosion-proof

Temperature Sensor

All pumps are equipped with a temperature sensor in each motor winding. In standard pumps, the connections for the temperature sensor are fed via the power cable to the outside and are to be connected in the electric control box using the T1 and T3 power cable endings in such a way that the motor automatically restarts after it has cooled down.

Instead of the standard sensor, the explosion-proof versions are equipped with a temperature sensor assembly that has a higher activation temperature. This is to be connected via the power cable endings T1 and T2 in such a way that after activation, a manual reset is necessary to restart the pump. The temperature sensor assembly must be connected in the control panel so that it switches off when it overheats.

Switch-off temperature of the sensors:

Motor Frame	Stator Winding T1+T3 Regulator	Stator Winding FM T1+T2 Limiter	Lower Bearing	Upper Bearing
T	140°C / 284°F	140°C / 284°F	80°C / 176°F	n/a
ET	125°C / 257°F	125°C / 257°F	n/a	n/a

Seal monitoring:

In case of a leak in the lower shaft seal, water enters the oil chamber and changes the resistance of the oil. The conductivity of the oil is monitored via one sensor to ground. In the motor housing, another sensor monitors for the resistance to ground in case of water intrusion. The sensors are to be connected via 2 cables (consult wiring diagram) from the pump connection cables in the control panel to a monitor galvanically separated from the probe circuit. The response sensitivity should be adjustable from 0-100 kΩ, the standard setting being 50 kΩ.

FM pumps: The sensors are connected via 2 cables (labelled S1 and S2) of the pump connector cable in the switching system to an evaluation device with an electrically isolated special circuit.

3.3.4. Sealing / Seal Housing

Sealing is accomplished in GRP24 and larger models by two silicon carbide mechanical seals in a tandem arrangement, acting independently from each other. In smaller models, sealing is accomplished by a silicon carbide lower mechanical seal, and a nitrile rubber (Buna N) upper lip seal. The seal housing is situated between the motor and the pump housing. It consists of the bearing housing and the pressure cover, which together form the sealing cavity with containing white mineral oil. Monitoring possibilities are available using the inspection plug on the bearing housing and optional electronic monitoring.

3.3.5. Jacketed Pump Option

The cooling jacket has been supplied based upon the specified operating conditions of this application. It is important this jacket is functioning properly, or the internal motor components could become damaged. Several cooling configurations are available depending upon customer preference and system requirements.

You must know what configuration of cooling system is to be used with the pump prior to installation. In some cases, field test results may indicate a change of cooling method is required. Consult factory for necessary changes to the pump.

COOLING REQUIREMENTS

Standard Media Cooled –

This construction does not require any external piping and it is completely self-contained. This design is suitable for the routine collection system application. No pump modifications are required.

3.3.7. Volute

The volute depending on the model, will have one of several discharge connections. Please consult an available drawing or your local HOMA distributor if you need help identifying the discharge connection on your pump.

3.3.8. Impeller

The impeller is fastened directly to the motor shaft and driven by it. GRP pumps are only available with an open multi-channel impeller.

3.3.9. Cutter system

The cutter system includes a fixed cutting ring and a cutter head which is mounted on the motor shaft. Thereby the cutter head turns with motor rotation speed and cut all solids in the sewage. Both parts consist of stainless steel hardened to HRC55.

4. Package, Transport, Storage

4.1. Delivery

On arrival, the delivered items must be inspected for damage and a check made that all parts are present. If any parts are damaged or missing, the transport company or the manufacturer must be informed on the day of delivery. Any claim made at a later date will be deemed invalid. Damage to parts must be noted on the delivery or freight documentation.

4.2. Transport

Only the appropriate and approved fastening devices, transportation means and lifting equipment may be used. These must have sufficient load bearing capacity to ensure that the product can be transported safely. If chains are used they must be secured against slipping.

The personnel must be qualified for the tasks and must follow all applicable national safety regulations during the work. The product is delivered by the manufacturer/shipping agency in suitable packaging. This normally precludes the possibility of damage occurring during transport and storage.



Never lift the pump by its power cable!

Ne jamais soulever la pompe par son câble d'alimentation !

4.3. Storage

Newly supplied products are prepared that they can be stored for 1 year. The product should be cleaned thoroughly before interim storage.

The following should be taken into consideration for storage:

- Place the product on a firm surface and secure it against falling over. Submersible mixers and auxiliary lifting devices should be stored horizontally, submersible sewage pumps and submersible motor pumps should be stored horizontally or vertically. It should be ensured that they cannot bend if stored horizontally.



Falling Hazard!

Never leave the pump unsecured!

Risque de chute !

Ne jamais laisser la pompe sans surveillance !

- The product has to be stored in a place free from vibrations and agitation to avoid damage to the ball bearings.
- The device should be stored in a dry place without temperature fluctuation.
- The product may not be stored in rooms where welding work is conducted as the resulting gases and radiation can damage the elastomer parts and coatings.
- Be careful to not remove or damage the corrosion resistant coatings.
- Any suction or pressure connections on products should be closed tightly before storage to prevent impurities.
- The power supply cables should be protected against kinking, damage and moisture.
- The cable will wick water into the pump if it is not protected properly. Power cable lead should be covered with shrink tubing or suitable sealing material during storage.



Beware of electrical current!

Damaged power supply cables can cause fatal injury! Defective cables must be replaced by a qualified electrician immediately.

Attention au courant électrique !

Des câbles d'alimentation endommagés peuvent provoquer des blessures mortelles ! Les câbles défectueux doivent être remplacés immédiatement par un électricien qualifié.



Beware of moisture!

Moisture penetrating cables can damage them and render them useless. Therefore, never immerse cable ends in the pumped fluid or other liquids.

Attention à l'humidité !

L'humidité qui pénètre dans les câbles peut les endommager et les rendre inutilisables. Par conséquent, ne jamais immerger les extrémités des câbles dans le fluide pompé ou dans d'autres liquides

- The machine must be protected from direct sunlight, heat, dust, and frost. Heat and frost can cause considerable damage to impellers, rotors and coatings.
- The impeller must be turned at monthly intervals. This prevents the bearing from locking and the film of lubricant on the mechanical shaft seal is renewed. This also prevents the gear pinions (if present on the product) from becoming fixed as they turn and also renews the lubricating film on the gear pinions (preventing rust film deposits).



Beware of sharp edges!
Sharp edges can form on rotors and impellers. There is a risk of injuries. Wear protective gloves.

Attention aux bords tranchants !
Les bords tranchants peuvent se former sur les rotors et les turbines. Il y a un risque de blessures. Porter des gants de protection.

- If the product has been stored for longer than six months it should be cleaned of impurities such as dust and oil deposits before start-up. Rotors and impellers should be checked for smooth running, housing coating and damage.
- After remaining in storage for longer than one year, it is necessary to change the oil in the seal chamber. This is necessary even if the pump has never been run, due to natural deterioration of mineral oil.

Before start-up, the filling levels (oil, cooling fluid etc.) of the individual products should be checked and topped up if required. Please refer to the machine data sheet for specifications on filling. Damaged coatings should be repaired immediately. Only a coating that is completely intact fulfils the criteria for intended usage!

If these rules are observed, your product can be stored for a longer period. Please remember that elastomer parts and coatings become brittle naturally. If the product is to be stored for longer than 6 months, we recommend checking these parts and replacing them as necessary. Please consult the manufacturer.

4.4. Returning to the supplier

Products which are delivered to the plant must be clean and correctly packaged. In this context, clean means that impurities have been removed and decontaminated if it has been used with materials which are hazardous to health. The packaging must protect the product against damage. Please contact the manufacturer before returning!

5. Installation and initial commissioning

5.1. General

To avoid damage to the lifting unit during installation and operation, the following points must be observed:

- The installation work must be performed by qualified personnel, in compliance with safety regulations.
- The pump must be inspected for damage prior to installation.
- For level controls, pay attention to the minimum water coverage.
- Air bubbles in the volute and pipework must be avoided (by suitable ventilation devices or a slight incline of the pump).
- Protect the pump from frost.
- The lifting device must have a maximum load capacity which is greater than the weight of the pump with attachments and cable.
- The power lines of the pump must be laid in such a way, that a safe operation and easy assembly/disassembly is ensured.
- The power lines must be fixed properly in the operating room to prevent the cable from hanging loosely. Depending on the cable length and weight, a cable holder must be attached every 2-3 m.
- The foundation/structure must have sufficient strength for secure and functionally correct fastening of the pump. The operator is responsible for this.
- Verify low level lockout is functioning.
- Use baffles for the inlet. This prevents air entry into the pumping medium, which can lead to unfavorable operating conditions and result in increased wear.
- Do not install more than one check valve into any piping system or problems will occur.

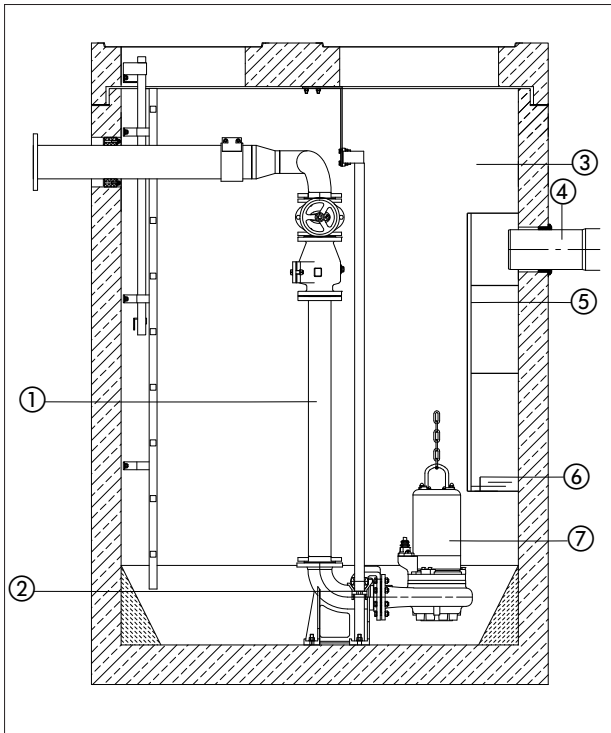

No.	Description
1	Pipe
2	Coupling system
3	Wet well
4	Inlet
5	Baffle plate
6	min. liquid level
7	Pump

External Seal Probe Installation Procedure

Mechanical Seal Leak Detection probe has been loose to protect from shipping damage. Please follow this procedure to install the probe.

- Lay pump on its side with the plug on the seal chamber facing upwards as indicated.
- Unscrew the plug with the proper wrench, taking care not to damage the sealing surface.
- Verify that seal chamber oil level is within $\frac{1}{4}$ " of the indicated value. Measurement is from oil level to the top of hole. See IOM Manual for seal chamber oil volume, if required.
- Remove the new sealing gasket from package and install it onto the seal probe plug.
- Install the seal probe with gasket into the opening, taking care not to damage the cable. Then tighten the seal probe with the proper wrench until snug. Do not overtighten. Once tight, verify the seal gasket is properly seated and the cable is not pinched or twisted. **NOTE:** At installation of the seal probe be careful not to bind the seal probe cord as it is being installed into the pump.
- Lift pump into a vertical position and inspect for any leaks.
- Secure seal probe cable to pump body and power cable with tytraps before installing pump.

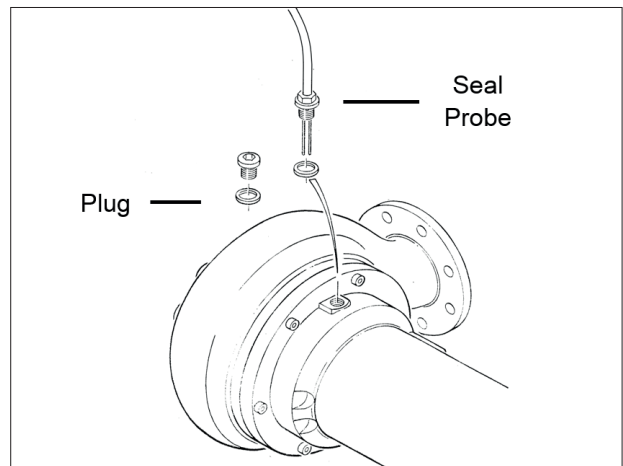

5.2. Installation



Risk of falling!

When installing the pump and accessories, work is carried out directly on the water's edge! Carelessness or wearing the wrong shoes can lead to falling. This is life threatening! Take all safety precautions to prevent this.

Risque de chute !

Lors de l'installation de la pompe et des accessoires, les travaux sont effectués directement au bord de l'eau ! La négligence ou le port de mauvaises chaussures peuvent entraîner une chute. Ceci pose un danger de mort ! Prenez toutes les précautions de sécurité pour éviter cela.

Torque Values

PUMP MODEL	Bolts Anchors	SIZE	TORQUE
Autocoupling	8	M16X60mm	146 Nm / 108 ft lb
	4	M16	100 Nm / 74 ft lb
Ring stand	4	M16x25mm	146 Nm / 108 ft lb

Notes:

- Flange bolts must be tightened in cross pattern to avoid damage to the raise face flanges.
- Standard flange bolts are 316SS
- Standard anchors are plated steel.
- Autocoupling systems include qty. 4 M12 anchors for the upper bracket. Torque to 51 Nm / 38 ft lb.
- Anchor bolt holes should be drilled to the actual diameter of the anchor (M12 anchor requires 12mm diameter hole).

Submerged installation on ring stand

Attach the ring stand (available as an accessory) with screws to the pump suction nozzle. 90° connection-elbow or connection loop to the pressure port of the pump, mount pressure line. Gate valves and check valves may need to be installed in accordance with local regulations. The pressure line must be fitted free of tension, when using a hose, ensure it is laid kink-free. Secure the pump by the handle with a cable or chain, and lower it into the pumping medium. Properly position power cable and chain so they stay above the pump and connate enter the pump suction.

Wet installation with automatic coupling system

The following instructions apply to the installation of the original HOMA Autocoupling system:

- Determine the approximate position of the position of the base elbow and the upper pipe bracket for the guide tubes, using a plumb bob where necessary.
- Check the correct installation dimensions of the pump(s) (see dimensional drawings in the appendix).
- Drill mounting holes for the guide rail bracket on the inside edge of the shaft opening. If this is not possible due to the space available, the guide rail bracket can also be mounted in an offset position with a 90° folded plate on the underside of the shaft cover. Provisionally fasten the guide rail bracket with 2 screws.
- Align the base elbow to the shaft floor, use a plumb bob from the pipe bracket- the guide tubes must be exactly perpendicular! Fasten the base elbow to the wet well floor using anchor bolts. Ensure that the base elbow is exactly horizontal! If the wet well floor is uneven, support the bearing surface accordingly.
- Mount the pressure pipes with fittings free of tension according to the usual mounting principles.
- Insert both guide rails into the eyelets on the base elbow and cut to size according to the position of the guide rail bracket. Partially unscrew the guide rails bracket, insert them into the guide rails and fasten the bracket. The guide rails must be positioned with no play at all, otherwise vibration will occur during operation of the pump.
- Clean the wet well of any solid material (debris, stones, etc.) before commissioning.
- Mount the guide claw on the pump discharge (thread or flange connection). Ensure that the rubber profile is correctly seated in position in the guide claw (as a seal against the coupling base), so that it will not fall out when lowering the pump. See graphic below
- Attach the chain to the pump handle or lifting lugs. Insert the pump with the guide rails in the guide claw ears. Lower the pump into the wet well. If the pump is seated on the base elbow, it automatically seals itself off to the pressure line and is ready for operation.
- Hang the end of the retrieval chain from a hook at the wet well opening.
- Hang the motor connection cable of the pump in the shaft at an appropriate length, with strain relief. Make sure that the cables can not be bent or damaged.

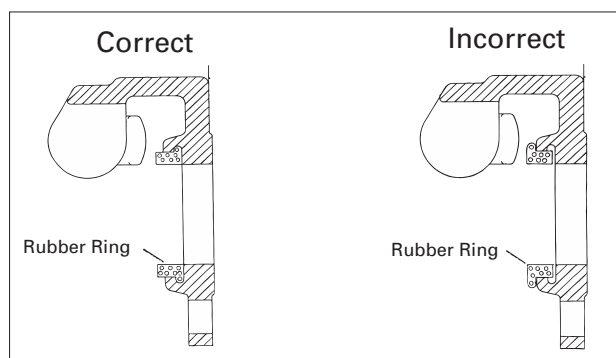

Dry Installation

Foundation and Piping Requirements:

General

The following recommendations are basic guidelines which are intended to outline basic requirements in the design of the dry pit station. It is essential that a licensed professional engineer be retained by the owner to design the station and all support structures.

Foundations

Foundations may consist of any structure heavy enough to provide permanent rigid support for the pump and inlet elbow stand. Concrete foundations built up from the solid ground are the most commonly used. The concrete floor shall be level. The space required by the inlet stand and the location of the foundation anchor bolts are shown on the outline dimension drawing. Foundation bolts are to be embedded in the concrete.

Suction Piping

Suction piping should be at least as large as the pump inlet elbow suction. If reducers are utilized they should be of the conical type. If the liquid source level is below the volute horizontal centerline, the reducer must be eccentric and installed with the level side up. If the liquid level is above the pump volute horizontal centerline, either eccentric or concentric reducers may be used. Suction piping should be run as straight as possible. All pipe flange joints should be gasketed to prevent air from entering the pipe. High points that may collect vapor are to be avoided. Isolation valves such as gate valves can be installed in order to facilitate the removal of the pump for maintenance. Any valve installed in the suction line should be installed with the stems horizontal.

Discharge Piping

A check valve and isolation valve shall be installed in the discharge line. The check valve should be installed between the pump discharge flange and the isolation valve. If pipe increasers are used on the discharge line, they should be placed between the check valve and the pump. The inlet elbow stand allows the pump to be installed in a stationary position in a dry pit. Place the inlet stand in position and tighten the anchor nuts.

Lower the pump on to the top flange of the inlet stand. DO NOT ALLOW SLACK ON THE LIFTING CABLE UNTIL THE PUMP IS BOLTED DOWN. Make sure the flange bolt holes align with the mounting holes on the underside of the volute. Secure the pump to the mounting flange with the fasteners that are specified in the accessory fastener selection table below.

Vent Valve Installation

HOMA dry pit pumps are supplied with a valve and fitting that must be installed and maintained to ensure the proper performance of these pumps. The opening for this valve is located on the base of the motor cap near the mounting screws. The pump is shipped with a plug installed which must be removed prior to start up. This opening is a metric straight thread and requires an adapter included with the valve and fitting hardware. It is also recommended that a length of hose be attached to the valve and routed back to the sump.

Note: Leave vent valve open in wet pit pump application to prevent air entrapment in jacket.

5.3. Use of chains

Chains are used to lower a pump in the operating space or to pull it out. They are not intended to secure a floating pump. Intended use is as follows:

- Fasten one end of the chain on the handle of the pump provided for this purpose. If your pump has two ring bolts as an attachment point, you must use a double-strand chain. When doing so, the angle of inclination of the chain strands must be between 0° and 45°.
- Attach the other end to the lifting device.
- Ensure tension on the chain, and then lift the pump in a slow and controlled manner.
- Gently lower the pump into operating space and lower it gently.
- Lower the pump to the operating point and make sure that the pump has a secure footing or the coupling system is engaged correctly.
- Remove the chain from the lifting device and secure it to the safety chain, which is located at the top of the operating room. This ensures that the chain can not fall into the operating area and constitute a danger to anyone.

Please note the following diagrams during installation.

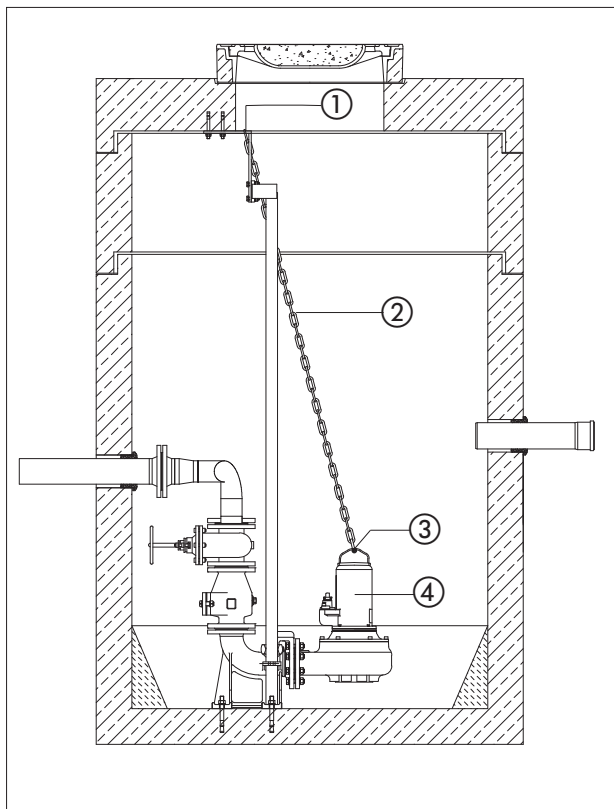

No.	Description
1	Chain guard
2	Chain
3	Handle
4	Pump

5.4. Initial operation

This chapter contains all the important instructions for operating personnel for the safe commissioning and operation of the machine. The following information must be strictly adhered to and checked:

- Type of installation
- Operating mode
- Minimum/max water coverage. Immersion depth

After a long downtime, these specifications are also to be checked and any defects are to be rectified! The operation and maintenance manual must always be kept with the machine, or be kept in a designated place where it is always accessible for all of the operating personnel.

To avoid injury to persons or damage during operation of the machine, the following points must be observed:

- The initial operation may only be carried out by qualified and trained personnel accompanied by an authorized HOMA representative following the safety instructions.
- All staff working on the machine must receive, read, and understand the instructions.
- Activate all safety devices and emergency stop switches before initial operation.
- Electrical and mechanical adjustments may only be performed by professionals.
- This machine is only suitable for use at the specified operating conditions.

5.5. Preparatory work

This pump has been designed so that it will operate reliably and for long periods under normal operating conditions. This requires, however, that you comply with all advice and instructions.

Please check the following points:

- Cable routing- no loops, slightly taut
- Liquid temperature and immersion depth check- see machine data sheet
- If a hose is used on the discharge side, it should be flushed before use with fresh water so that no deposits cause blockages
- For wet installation, the wet well must be cleaned
- The pressure and suction side pipe systems are to be clean and all valves are to be opened.
- If the pump is jacketed with media cooling, the jacket must be completely bled of air, i.e. it must be completely filled with the medium and there may be no more air in it. The venting can be done by suitable ventilation devices in the system, or, if available, by venting screws at the outlet nozzle.
- Check the accessories, pipe system and suspension unit for firm and correct fit
- Review the present level control.
- An isolation test and a level control must be carried out before commissioning.

5.6. Electrical

When installing and selecting of electrical lines and when connecting the motor, the relevant local and NEC regulations must be observed. The motor must be protected by a motor protection circuit breaker. Connect the motor per the wiring diagram. Pay attention to the direction of rotation! If rotation is in the wrong direction, the machine will not perform to specifications. And can be damaged under adverse circumstances.

Check the operating voltage, and ensure there is uniform power consumption by all phases in accordance with the machine data sheet.

Make sure that all temperature sensors and monitoring devices, e.g. sealing chamber control, are connected and tested for function.



Risk of electrocution!

Improper use of electricity can be fatal! All pumps with exposed cable ends must be connected by a qualified electrician.

Risque d'électrocution !

Une mauvaise utilisation de l'électricité peut être fatale ! Toutes les pompes dont les extrémités de câble sont exposées doivent être raccordées par un électricien qualifié.

All electrical work shall be carried out under the supervision of an authorized, licensed electrician. The present state adopted edition of the National Electrical Code as well as all local codes and regulations shall be complied with.

5.6.1 Verification of power supply

Prior to making any electrical connections or applying power to the pump, compare the power supply available at the pump station to the data on the unit's nameplate. Confirm that both voltage and phase match between pump and control panel.

5.6.2 Power lead wiring

HOMA pumps may be provided with 1 or more cables, depending on motor horsepower and operating voltage. Power leads L1, L2, & L3 may be provided as single conductor, or as multiple conductors. Multiple conductor configurations may use leads from separate cables, or may use two conductors within one cable. Please refer to wiring diagram in the appendix for specific connection details. The pump must be connected electrically through a motor starter with proper circuit breaker protection in order to validate warranty. Do not splice cables.

5.6.3 Thermal switch wiring

Pumps are equipped with thermal switches embedded in the stator windings which are normally closed, automatically resetting switches. Switches will open when the internal temperature rises above the design temperature, and will close when the temperature returns to normal. Thermal switches must be wired to a current regulated control circuit in accordance with the NEC. Identify thermal switch leads marked T1 and T2 in the power or control cable.

The resistance across the leads will be 0.5 Ohms. Thermal leads must be connected to the thermal overload relay located in the control panel. Thermal switch leads must be connected to validate warranty.

Note: All sizes of Class 1, Div. 1 pumps for hazardous service must have thermal switch leads connected to a current regulated control circuit in accordance with NEC.

5.6.4 Seal probe wiring

The mechanical seal leak detector probe utilized in the pump is a conductive probe which is normally open. The intrusion of water into the seal chamber completes the electrical circuit. Control panel provisions will sense this circuit closure, and will provide indication or alarm functions depending on the panel design.

Either single or dual wire systems may be provided. Single wire systems utilize one energizing conductor, and the pump casing and neutral lead as the ground or return portion of the circuit. The dual wire systems utilize two separate conductors for each leg of the circuit.

With either system, the seal probe leads must be wired into a control circuit provided in the control panel. This control circuit must energize the probe with a regulated power source, and sense the closed circuit in event of water intrusion. Indication and alarm functions must also be provided in the control circuit. Please see control panel wiring diagram for seal probe connection points.



For Hazardous Area Classification Pumps, leak detector circuit must be in conformance with applicable NEC codes and regulations.

Pour les pompes classées en zone dangereuse, le circuit du détecteur de fuites doit être conforme aux codes et réglementations NEC applicables.

5.6.5 Start / Run Capacitors and Relays

All single phase motors require start and run capacitors along with a start relay to operate. Capacitors and relays must be sized for the specific motor.

Capacitors are sized based on ideal conditions.

The run capacitor may need to be resized to match the available field voltage. Each cap kit shipped is supplied with a wiring diagram and start up procedure.

5.6.6 Single Phase Pump Start-Up Procedure

Run Capacitor sizing can vary depending on the incoming supply voltage provided. HOMA Single Phase pumps are provided with Start and Run Capacitor(s) sized for 220-230V under load. Frequently, the available line voltage is considerable different than indicated, and the Run capacitor(s) may need to be resized to match the available field voltage. The following procedure will allow you to verify proper operation of your single phase pump, and/or make necessary changes to you capacitors to correct for your power supply.

After verifying wiring is in accordance with your pump requirements, start pump and record the following readings from each of the (3) pump cable leads.

Current under load:

U1 _____ Amps, > U2 _____ Amps, > Z2 _____ Amps

U1: (Should be) highest reading

U2: middle reading

Z2: lowest reading

Lead U1 (common) should have the highest current reading. Lead Z2 (start) should have the lowest reading.

If Z2 current draw is greater than the current draw of either U1 or U2, a smaller size Run capacitor (lower microfarad rating) is required to correct the condition. Example: If a 60 µf Run capacitor was supplied, change to a 50 µf Run capacitor and check current readings. Typically, only one step down in capacitor size is required, but in certain instances 2 steps may be required.

() The standard capacitor kit provided includes:

_____ µf start capacitor

_____ µf run capacitor.

() Additional run capacitors have been included for use in tuning the pump to match available line voltages for optimum performance.

_____ µf run capacitor

_____ µf run capacitor

_____ µf run capacitor

This form is provided for your use in optimizing the performance and service life of your single phase pumps, and is applicable to most Capacitor Start/Capacitor Run motors. Please contact our customer service with any questions or if you require any additional information or assistance.

5.7. Direction of rotation

Rotation Direction Check

All pumps have the proper rotation direction when connected to a clockwise field of rotation (U, V, W-> L1, L2, L3). If the pump rotation is backwards, swap two lead and reconnect. For smaller pumps, the check can be done by observing the pump's movement while starting.

To do this, set the pump lightly on the ground in a perpendicular fashion and switch it on briefly. When observing from above, the pump itself moves slightly in a counter-clockwise direction when rotating in the right direction. The correct direction of rotation of the pump is achieved once the pump moves counter-clockwise, since when viewed from above, the motor starts in a clockwise direction.

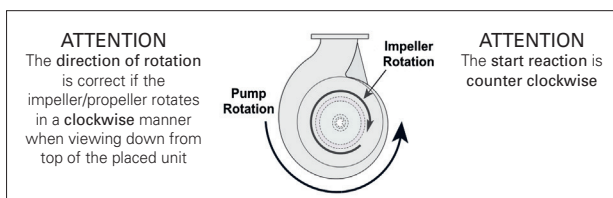

For large pumps, the direction can also be determined by looking through the pump discharge into the volute. Briefly run the motor in order to verify it is running clockwise.



Caution – Rotating Impeller!

Do not touch the rotating impeller or reach into the volute through the pressure outlets!

Never reach into the volute or touch any rotating parts during operation. Switch the machine off and wait until all rotating parts have come to a stop prior to carrying out maintenance and repair work!

Attention - Turbine en rotation !

Ne pas toucher la turbine en rotation ni pénétrer dans la volute par les orifices de pression !

Ne jamais mettre la main dans la volute ou toucher les pièces en rotation pendant le fonctionnement. Mettre la machine hors tension et attendre l'arrêt de toutes les pièces en rotation avant d'effectuer des travaux d'entretien et de réparation !

It is also possible to check the direction of rotation with a "motor and phase rotation indicator". This measurement device is held from the outside up to the motor housing of the switched-on pump and displays the direction of rotation via an LED.

5.8. Motor protection

The minimum requirement is a thermal relay/motor protection circuit breaker with temperature compensation, differential triggering, and reclosing lock in accordance with VDE 0660 or similar national regulations. If the equipment is connected to power grids where problems often occur, we recommend the additional use of protective devices (e.g. overvoltage protection or under voltage protection or phase failure relays, lightning protection, etc.). When connecting the machine, the local and legal requirements must be adhered to.

5.9. Variable Frequency Drives

Special considerations must be taken when operating pumps with variable frequency drives (inverters). The inverter circuit design, horsepower required by pump, motor cooling system, power cable length, operating voltage, and anticipated turndown ratio must be fully evaluated during the design stage of the installation.

As a minimum, properly sized load reactors and filters must be installed between the inverter and the pump to protect the pump motor from damaging voltage spikes.

Warranty coverage will not be provided on any pump motor that is operated with a variable frequency drive, unless the load side of the inverter is properly isolated from the pump.

5.10. Types of startups

Types of startup using with cables with exposed ends

Direct start up

At full load, the motor protection circuit breaker should be set to the rated current. In partial load operation it is recommended to set the motor protection circuit breaker 5% above the measured current at the operating point.

Soft start

At full load, the motor protection should be set to the rated current. In partial load operation, it is recommended to set the motor protection 5% above the measured current at the operating point. The starting time must be max. 5s. The starting voltage is to be set at 40% of the rated voltage according to the rating plate.

Start up with HOMA GO switch

Plug the connector into the socket provided and press the on/off switch on the GO switch.

5.10.1. After start up

The nominal current is briefly exceeded on start-up. After completion of this operation, the operating current should not exceed the nominal current. If the motor does not start immediately after switching on, it must be shut down immediately.

The switch breaks specified in the technical data must be adhered to before turning on again. If there is a new fault, the machine must again be shut down immediately. The machine may only be started up again after troubleshooting.

The following items should be checked:

- Current consumption (permissible deviation between phases max. 5%)
- Voltage difference between the individual phases (max. 1%)
- Switching frequency and pauses (see Technical Data)
- Air entry at the inlet- if necessary, a baffle plate must be attached
- Minimum water coverage, level control, dry run protection
- Smooth running
- Check for leaks: if necessary, take the necessary steps according to the chapter „Maintenance“

6. Maintenance

6.1. General

The machine and the entire system must be inspected and maintained at regular intervals. The time limit for maintenance is set by the manufacturer and applies to the general conditions of use. The manufacturer should be consulted if the system is to be used with corrosive and/or abrasive pumped liquids, as the time limit between inspections may need to be reduced.

Note the following information:

- The operating and maintenance manual must be available to the maintenance personnel and its instructions followed. Only the repair and maintenance measures listed here may be performed.
- All maintenance, inspection and cleaning work on the machine and the system may only be carried out by trained specialists exercising extreme care in a safe workplace. Proper protective clothing is to be worn. The machine must be disconnected from the electricity supply before any work is carried out. There must be no way that it can be inadvertently switched on.
- Above a weight of 50kg, only hoisting gear which has been officially approved and which is in a technically perfect condition should be used for lowering and raising the machine.

Make sure that all fastening devices, ropes and safety devices are in a technically perfect condition. Work may only commence if the auxiliary hoisting gear has been checked and found to be in perfect working order. If it is not inspected, danger to personnel may result!

- Wiring work on the machine and system must be carried out by an electrician. For machines approved for work in areas subject to explosion danger, please refer to the "Explosion protection in accordance with the regulation" chapter.
- When working with inflammable solvents and cleaning agents, fires, unshielded lighting and smoking are prohibited.
- Machines which circulate fluids hazardous to health, or which come into contact with them, must be decontaminated. It must be ensured that no dangerous gases can form or are present.
- Ensure that all necessary tools and materials are available. Tidiness and cleanliness guarantee safe and problem-free operation of the machine. After working on the machine all cleaning materials and tools should be removed from it. All materials and tools should be stored in an appropriate place.
- Operating supplies such as oil and lubricants must be collected in appropriate vessels and properly disposed. Appropriate protective clothing is to be worn for cleaning and maintenance jobs. Only lubricants expressly recommended by the manufacturer may be used. Oils and lubricants should not be mixed. Only use genuine parts made by the manufacturer.

A trial run or functional test of the machine must be performed as instructed in the general operating conditions.

Oil type: white mineral oil. Used oil is to be disposed accordingly.

When using white mineral oil, note the following:

- Machines which have previously been operated using other lubricants must first be thoroughly cleaned before they can be operated using white mineral oil.

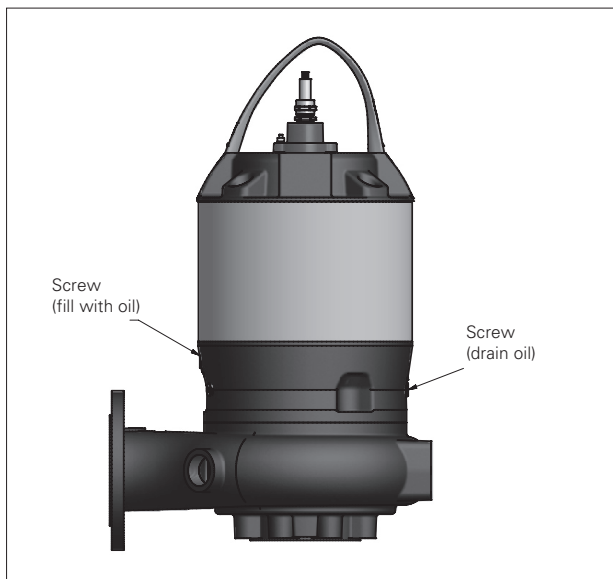
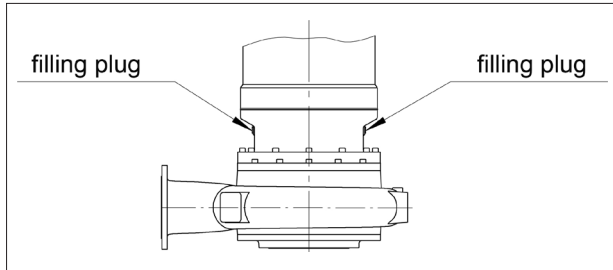

6.2 Maintenance intervals

Before initial start-up or after a longer period of storage:

- Check insulation resistance
- Check oil level in seal chamber
- Check that impeller rotates freely by hand

Monthly:

- Monitor the amperage and voltage
- Check the used relays for proper operation

Every six months:

- Visual inspection of the power supply cable
- Visual inspection of the cable holder and the cable bracing
- Visual inspection of accessories, e.g. the suspension device and hoisting gears

8,000 operating hours or after two years, whichever is earlier:

- Check the insulation resistance
- Check the lubricant in the seal chamber
- Functional inspection of all safety and control devices

15,000 operating hours or after five years, whichever is earlier:

- General overhaul

If it is used in highly abrasive or corrosive material, the maintenance intervals should be reduced!

6.3. Maintenance tasks

Monitoring the current consumption and voltage

The current consumption and voltage is to be monitored periodically for all winding phases. This remains constant during normal operation. Slight fluctuations are a result of the composition of the pumped fluid. The current consumption can assist in early detection and correction of damage and/ or faulty operation in the impeller/propeller, bearings and/ or the motor. More extensive resulting damage can thus be largely prevented and the risk of a total failure can be reduced.

Checking the used relays for posistors, oil chamber monitors, etc.

Check the relays used are functioning fault-free. Defective devices must be immediately replaced, because these cannot ensure safe operation of the machine. The test procedure details should be followed closely (in the operating instructions for each relay).

Checking the insulation resistance

To check the insulation resistance, the power supply cable must be disconnected. The resistance can then be measured with an insulation tester (measuring voltage = 1000V DC).

The following values may not be exceeded:

- The insulation resistance may not be below 20 MΩ during initial operation. For all further measurements the value must be greater than 2 MΩ.
- Insulation resistance too low: Moisture may have penetrated the cable and/ or the motor.

Do not connect the machine, consult manufacturer!

Visual inspection of power supply cables

The power supply line must be examined for bubbles, cracks, scratches, chafed areas and/ or crushed sections. If damage is found, the power cable must be exchanged immediately.

The cables may only be changed by the manufacturer or an authorized/certified service workshop. The machine may not be used again until the damage has been adequately rectified.

Visual examination of the cable holders (carabiners) and the cable bracing

When the machine is used in basins or pits, the lifting cables/cable holders (carabiners) and the cable bracing are subject to constant wear. Regular inspections are necessary in order to prevent the lifting cables/cable holders (carabiners) and/ or cable bracing from wearing out and to prevent the electricity cable from being damaged. The lifting cables/cable holders (carabiners) and the cable bracing are to be immediately replaced if any signs of wear appear.

Visual inspection of accessories

Inspect accessories such as suspension units and hoisting gear to check whether they are secured in a stable manner. Loose and/or defective accessories should be repaired immediately or replaced.

Oil Level check in Seal Chamber

Visual Inspection of Oil Chamber:

Oil Level

Please take the precise filling quantity from the spare parts list or contact the manufacturer with the pump serial number.

Oil Condition

The condition of the mechanical seals can be visually inspected as follows: Put the pump in horizontal position, so that the oil chamber drain plug is on top (for larger pumps: one of both oil chamber screws). Remove the drain plug and take out a small quantity of oil. The oil becomes greyish white like milk if it contains water. This may be the result of defective shaft seals. In this case the condition of the shaft seals should be checked by a HOMA Service shop. Oil type: Mineral Oil
Used oil has to be disposed according to the existing environmental rules and regulations.

Visual Inspection of Coolant Chamber (Closed Loop Pumps Only):

Quantity of Coolant

Please take the precise filling quantity from the spare parts list or contact the manufacturer with the pump serial number.

The condition of the mechanical seals can be inspected controlled as follows: Set up the pump vertically and unscrew the ventilation screw located above and remove a small quantity of coolant. If the cooling liquid becomes grey (original color: light pink or light orange) this may be the result of defective shaft seals. In this case the condition of the shaft seals should be checked by a HOMA Service shop.

Type: Silica-free propylene glycol-based antifreeze (available on request). Used cooling liquid has to be disposed according to the existing environmental rules and regulations.

Functional inspection of safety and control devices

Monitoring devices are temperature sensors in the motor, oil chamber monitors, motor protection relays, overvoltage relays, etc.

Motor protection and overvoltage relays and other trip elements can generally be triggered manually for test purposes. To inspect the oil chamber monitor or the temperature sensor, the machine must be cooled to ambient temperature and the electrical supply cable of the monitoring device in the switch cabinet must be disconnected. The monitoring device is then tested with an ohmmeter. The following values should be measured:

Bi-metal sensor: Value = "0" - throughput

PTC sensor: A PTC sensor has a cold resistance of between 20 and 100 Ω . For 3 sensors in series this would result in a value of between 60 and 300 Ω .

PT 100 sensor: PT 100 sensors have a value of 100ohms at 0°C. Between 0°C and 100°C this value increases by 0.385 Ω per 1°C. PT 20 sensors have a value of 107.7 Ω at 20°C.

Moisture sensor: This value must approach infinity. If there is a low value, there may be water in the oil. Also observe the instructions of the optionally available evaluation relay.

In the case of larger deviations, please consult the manufacturer.

Please consult the appropriate operating manual for details on inspecting the safety and monitoring devices on the auxiliary lifting gear.

General overhaul

During this the bearings, shaft seals, O rings and power supply cables are inspected and replaced as required in addition to normal maintenance work. This work may only be conducted by the manufacturer or an authorized service workshop.

Changing the oil

The drained oil must be checked for dirt and water content. If the oil is very dirty and shows water intrusion, it must be changed again after four weeks. If there is again water in the oil then, it seems likely that a seal is defective. In this case, please consult the manufacturer. If a oil chamber or leakage monitoring system is being used, the display will light up again within four weeks of changing the oil if a seal is defective.

The general procedure for changing oil is as follows: **Switch off the machine, let it cool down, disconnect it from the power supply (have this done by an electrician), lock out tag out the control panel, clean it and place it vertically on a solid base. Warm or hot oil may be pressurized. The leaking oil may cause burns. For that reason, let the machine cool down to ambient temperature before you touch it.**

6.4. Sealing chamber

As there are several versions and designs of these motors, the exact location of the screw plugs varies depending on the pump unit used.

- Slowly and carefully remove the filling plug from the seal room.

Caution: The oil may be pressurized!

- Remove the drain plug. Drain the oil and collect it in a suitable reservoir. Clean the drain plug, fit with a new sealing ring and screw it in again. For complete drainage, the machine must be slightly tipped on to its side.

Make sure that the pump is on its side and secure!

- Fill lubricant by means of the opening in the filling plug. Comply with the specified lubricants and filling quantities.
- Clean the filling plug, fit with a new sealing ring and screw it in again.

7. Repairs

7.1. General

When carrying out repair work, the following information should always be noted:

- Round sealing rings as well as existing seals should always be replaced.
- Screw fixings such as spring washers should always be replaced.
- The correct torques must be observed.



In general, the following applies to repairs: Switch off the machine, disconnect it from the power supply (have this done by an electrician), clean it and place it on a solid base in a horizontal position. Secure it from falling over and/or slipping.

En général, les dispositions suivantes s'appliquent aux réparations : Éteindre la machine, la débrancher du réseau électrique (faire appel à un électricien), la nettoyer et la placer sur une base solide en position horizontale. Éviter qu'elle ne tombe et/ou ne glisse.

If not otherwise stated, the torque values of the below tables should be used. Values stated are for clean, lubricated screws. Fixing torque [ft lbs] for screws A2/A4 (Coefficient of friction = 0.2)

	A2/A4, Hardness class 70	A2/A4, Hardness class 80
	DIN912/DIN933	DIN912/DIN933
M6	5 ft lbs	9 ft lbs
M8	12.5 ft lbs	21 ft lbs
M10	24 ft lbs	43 ft lbs
M12	42 ft lbs	73.5 ft lbs
M16	103 ft lbs	180.5 ft lbs
M20	201.5 ft lbs	364.5 ft lbs

7.2. Changing the impeller

Abstract

This document will provide the proper procedure for the replacement of an impeller on a GRP pump. CAUTION: the cutters used on the GRP are sharp and can cause injury if handled improperly. Take care when handling and removing them.

Procedure

- Position and support pump upside down with the suction connection facing up.
- Mark the location of the suction cover to the volute to ease reassembly.
- Remove socket head cap screws that retain suction cover. Do not disturb the set screws for suction cover adjustment.
- Remove suction cover, taking care to protect the O Ring.
- Holding cutter head with suitable device loosen the impeller retaining bolt and remove.
- Remove cutter head from impeller. Carefully pull impeller off of shaft. Important: The impeller holds lower mechanical seal in place. Take care not to disturb mechanical seal.

- Verify impeller key is still properly positioned on shaft.
- Install new impeller onto shaft, and reinstall cutter head. Note: Take care to properly position dowel pin into locating hole in impeller.
- While holding the cutter head with suitable device, reinstall impeller bolt. Torque to 18 ft. lbs. (Use of Loctite 242 on impeller bolt is desirable)
- Reinstall suction cover, taking care to lubricate the O-ring before installation.
- Replace the retaining bolts for the suction cover. Torque to 12 ft. lbs.
- Rotate the cutter head and verify that no contact occurs between cutter and ring.
- Unit should now be ready for test operation. Return unit to normal orientation, connect power, and start pump. Some slight rubbing may be heard, and is acceptable. However, if severe grinding or rubbing is evident, adjust suction cover (with unit disconnected from power supply) until components move freely. This may require more than one adjustment to obtain proper clearance.

Notes: If oil is found leaking from the impeller/volute/seal area, the mechanical seal was not compressed properly during the impeller installation. Disassemble unit, and reinstall impeller properly, taking care to keep mechanical seal compressed until impeller bolt is secured.

Only OEM Parts may be used for replacement.

Inspecting and replacing these parts is performed by the manufacturer during the general overhaul or by specially trained personnel.

7.3 Spare Parts

In order to obtain spare parts identify the required parts, and contact authorized HOMA customer service with your order. Authentic HOMA parts shall be used to maintain warranty.



Explosion Proof pumps must be identified as such, and the pump serial number must be referenced for proper parts identification.

Les pompes antidéflagrantes doivent être identifiées comme telles et le numéro de série de la pompe doit être mentionné pour une identification correcte des pièces.

8. Shutdown

8.1. Temporary shutdown

For this type of shutdown, the machine remains installed and is not cut off from the electricity supply. For temporary shutdown, the machine must remain completely submerged so that it is protected from frost and ice. Make sure the wet well and the pumped fluid cannot be covered by ice. This ensures that the machine is always ready for operation. Carry out a monthly start-up and run the pump in operating conditions for 5 minutes.



Caution!

Only test the pump under the proper conditions of operation and use. Never run the machine dry. This can result in irreparable damage!

Mise en garde !

Ne tester la pompe que dans les conditions de fonctionnement et d'utilisation appropriées. Ne jamais faire fonctionner la machine à sec. Cela peut entraîner des dommages irréparables !

8.2. Final shutdown / storage

Switch off the system, disconnect the machine from the electricity supply and dismantle and store it. Note the following information concerning storage:



Beware of hot parts!

When removing the machine, be careful of the temperature of the housing components. These can heat up to well above 104°F. Let the machine cool down to ambient temperature before you touch it.

Attention aux composants chauds !

Lors du démontage de la machine, faire attention à la température des composants du boîtier. Ces appareils peuvent atteindre une température bien supérieure à 40°C. Laisser la machine refroidir à la température ambiante avant de la toucher

- Clean the machine.
- Store it in a clean, dry place, protect the machine against frost.
- Place it down vertically onto a firm foundation and secure it against falling.
- Support the cable at the cable entry assembly to help avoid a permanent deformation.
- Protect the ends of the electric power cable from moisture.
- Protect the machine from direct sunshine as a preventive measure against brittleness in elastomer parts and the impeller and casing coating.
- When storing the machine in a shop please remember: Radiation and gases which occur during electric welding destroy the elastomers of the seals.
- During lengthy periods of storage, regularly (for example every six months) turn the impeller or propeller by hand. This prevents indentations in the bearings and stops the rotor from rusting up.

8.3. Restarting after an extended period of storage

Before restarting the pump, it should be completely re-commissioned. Clean it of dust and oil deposits, then carry out the necessary maintenance actions (see "Maintenance"). Check that the mechanical shaft seal is in good order and working properly. Once this work has been completed, the machine can be installed (see "Installation") and connected to the electricity supply by a specialist. See "Start-up" for instructions on restarting.

Only restart the machine if it is in perfect condition and ready for operation.

9. Troubleshooting



In order to prevent damage or serious injury while repairing machine faults, the following points must be observed:

- Only attempt to repair a fault if you have qualified personnel. This means each job must be carried out by trained specialist personnel, for example electrical work must be performed by a trained electrician.
- Always secure the machine against an accidental restart by disconnecting it from the electric system. Lock out, tag out, and take appropriate safety precautions.
- Always have a second person make sure the machine is switched off in an emergency.
- Secure moving parts to prevent injury.
- Independent work on the machine is at one's own risk and releases the manufacturer from any warranty obligation.



Afin d'éviter tout dommage ou blessure grave lors de la réparation de la machine, les points suivants doivent être respectés :

- Ne tentez de réparer une déféctuosité que si vous disposez d'un personnel qualifié. Cela signifie que chaque travail doit être effectué par un personnel spécialisé formé, par exemple, les travaux d'électricité doivent être effectués par un électricien qualifié.
- Toujours sécuriser la machine contre un redémarrage accidentel en la déconnectant du système électrique. Verrouillez, étiquetez et prenez les mesures de sécurité appropriées.
- Demandez toujours à une deuxième personne de s'assurer que la machine est éteinte en cas d'urgence.
- Attachez les pièces mobiles pour éviter les blessures.
- Toute intervention indépendante sur la machine se fait à ses propres risques et libère le fabricant de toute obligation au titre de la garantie.

The machine will not start	
Cause	Solution
Electricity supply interrupted – short circuit or ground connection in the cable or motor windings	Have the motor and wires checked by a specialist and replaced if necessary
Fuses, the motor protection switch and/or monitoring devices are triggered	Have a specialist inspect the connection and correct them as necessary Have the motor protection switch adjusted according to the technical specifications, and reset monitoring equipment. Check that the impeller/propeller runs smoothly. Clean it or free it as necessary
The moisture sensors (option) has interrupted the power circuit (operator-related)	See fault: Mechanical shaft seal leaks, seal chamber monitor reports fault and switches the machine off

Machine runs but does not pump	
Cause	Solution
No pumped fluid	Open the container intake or valves
Intake blocked	Clean the intake, valve, suction port or intake strainer
Impeller/propeller blocked or obstructed	Switch off the machine, secure it against being switched on again and free the impeller/ propeller
Defective hose or piping	Replace defective parts
Intermittent operation	Check the control panel

The motor starts, but the motor protection switch triggers shortly after start-up	
Cause	Solution
The thermal trigger on the motor protection switch is incorrectly set	Have a specialist compare the setting of the trigger with the technical specifications and adjust it if necessary
Increased power consumption due to major voltage drop	Have an electrician check the voltage on each phase and rewire if necessary
Excessive voltage differences on the three phases	Have a specialist inspect the connection and the switching system and correct it as necessary
Incorrect direction of rotation	Swap the 2 phases from the mains supply
Impeller/propeller impeded by adhesive material, blockages and/or solid matter, increased current consumption	Switch off the machine, secure it against being switched on again and free the impeller/ propeller or clean the suction port
The pumped fluid is too dense	Contact the manufacturer

The machine runs, but not at the stated operating levels	
Cause	Solution
Intake blocked	Clean the intake, valve, suction port or intake strainer
Valve in the discharge line closed	Fully open the valve
Impeller/propeller blocked or obstructed	Switch off the machine, secure it against being switched on again and free the impeller/ propeller
Incorrect direction of rotation	Replace 2 phases on the mains supply
Air in the system	Check the pipes, pressure shroud and/or pump unit, and bleed if necessary
Machine pumping against excessive pressure	Check the valve in the discharge line, if necessary open it completely
Signs of wear	Replace worn parts
Defective hose or piping	Replace defective parts
Inadmissible levels of gas in the pumped liquid	Contact the factory
Two-phase operation	Have a specialist inspect the connection and correct it as necessary

The machine does not run smoothly and is noisy	
Cause	Solution
Machine is running in an impermissible operation range	Check the operational data of the machine and correct if necessary and/or adjust the operating conditions
The suction port, strainer and/or impeller/propeller is blocked	Clean the suction port, strainer and/or impeller/Propeller
The impeller is blocked	Switch off the machine, secure it against being switched on again and free the impeller
Inadmissible levels of gas in the pumped liquid	Contact the factory
Two-phase operation	Have a specialist inspect the connection and correct it as necessary
Incorrect direction of rotation	Replace 2 phases on the mains supply
Signs of wear	Replace worn parts
Defective motor bearing	Contact the factory
The machine is installed with mechanical strain	Check the installation, use rubber spacers if necessary

Mechanical shaft seal leaks, sealing chamber monitor reports fault and switches the machine off	
Cause	Solution
Increased leakage when running in new mechanical shaft seals	Change the oil
Defective sealing chamber cables	Replace the moisture sensors
Mechanical shaft seal is defective	Replace the mechanical shaft seal after contacting the factory

Further steps for troubleshooting

If the items listed here do not help you rectify the fault, contact our customer service. They can help you as follows:

- Telephone or written help from customer service
- On-site support from customer service
- Checking and repairing the machine at the factory

Note that you may be charged for some services provided by our customer support. Customer service will provide you with details on this.

10.1. Connection of pumps and mixers



Risk of electrocution!

Improper use of electricity can be fatal! All pumps with exposed cable ends must be connected by a qualified electrician.

Risque d'électrocution !

Une mauvaise utilisation de l'électricité peut être fatale ! Toutes les pompes dont les extrémités de câble sont exposées doivent être raccordées par un électricien qualifié.

10.1.1 Power cables

Pumps in Star 3-phase version

Cable identification Motor	Terminal in control cabinet
U1	U1
V1	V1
W1	W1
U2	U2
V2	V2
W2	W2

Pumps in Direct start version

Cable identification Motor	Terminal in control cabinet
U	U1
V	V1
W	W1

10.1.2 Control cables

Depending on the design of the pump/agitator, it may be that no separate control cable is used. In this case monitoring devices are run from the power cable.

Cable identification Motor	Monitoring system
Monitoring in winding	
T1 / T2	Temperature limiter (2 switches in series)
T1 / T4	Temperature controller (2 switches in series)
T1 / T2 / T3	Temperature limiter and controller
K1 / K2	PTC – Thermistor (3 thermistors in series)
PT1 / PT2	3 x PT100 individually installed
PT3 / PT4	
PT6 / PT6	
Bearings monitoring	
P1 / P2	PT100 upper bearing
P3 / P4	PT100 lower bearing
Seal monitoring	
S1 / S2	Seal monitoring in oil chamber
S3 / S4	Seal monitoring in connection compartment
S5 / S6	Seal monitoring in Motor compartment with 2 Electrodes
S7 / S8	Seal monitoring in Motor compartment with float switch
S9 / S10	Seal monitoring in Gearbox (Agitator)
S11 / S12	Seal monitoring in Leakage compartment (internal cooling)
Heating	
H1 / H2	Heating system



HOMA Pump Technology

390 Birmingham Blvd ▶ Ansonia, CT 06401

Phone: 203-736-8890 ▶ Fax: 203-736-8899

e-Mail: info@homapump.com ▶ Internet: www.homapump.com